

# **MAIN EXTENSION POLICY**

**Public Water Supply District #3**

**Of Jefferson County, Missouri**

**6/26/23**

4

**PREFACE – GUIDELINES OF PROCEDURE FOR WATER MAIN EXTENSIONS**  
**(Please refer to the Rules and Regulations, attached, for actual requirements)**

1. The initial submittal shall consist of:
  - a. Three (3) complete sets of water main extension plans.
  - b. All 3 sets are to be signed and sealed by a Professional Engineer, registered in the State of Missouri. One set is to be signed by the Fire Marshal of the Fire Protection District where the extension is to be made.
  - c. The subject set of plans shall have a location map of the subject water extension showing the nearest roadway system, property lines, street names, lot numbers, water main size, fittings, hydrants, and valves. Elevations and property adjacent to the proposed development shall also be shown on the plans. Water main to be installed off roadway easement on 15' easement dedicated to Water District No. 3. Plans shall reflect the estimated flow and pressure of the proposed extension calculated from current data.
  - d. Plans shall indicate a looped distribution system with no dead ends. Provisions shall be made to tie or loop the proposed system to existing water main situated adjacent to the proposed development. All easements and right of ways necessary to accommodate the proposed water distribution system shall be provided and dedicated to the Water District for Water District's use.
  - e. All mains shall be a minimum size of 8 inch or larger where required.
  - f. Completion of Form 10.1 and payment of the proper Application Fee.
  - g. Copy of Form 10.3 completed as much as possible at the time of submittal.
2. Submittals not meeting all requirements of (1) above will be returned without review.
3. Acceptable submittals will be reviewed under the direction of the District Engineer. If revisions are required, the Owner and/or their engineer will be notified.
4. Once the submittal meets the approval of the District Engineer, the project will be presented to the District's Board of Directors for approval. Board meetings are held the first Wednesday of each month. Submittals must be received at least 14 days prior to the Board Meeting to be considered for approval.
5. Once Board approval is granted, the following must be submitted or done before construction may begin:
  - a. The Construction Permit Fee per form 10.2 must be paid to the District.
  - b. The name and address of the Contractor must be furnished and said Contractor must meet the Bond and Insurance requirements of the District.
  - c. The Owner shall furnish a recorded or "recordable" plat of any subdivision and copies by the Missouri Registered Land Surveyor who prepared it, shall show all

easements required for the water main extension and it shall be signed by the Owner, with his/her signature notarized. The plat shall be submitted in printed form and on a USB flash drive in AutoCAD or DXF for use by the District.

- d. The project shall be staked out by a Land Surveyor or Professional Engineer, registered with the State of Missouri. The stake locations shall be shown on a set of plans, to be submitted to the district and the staking shall be inspected by the District.
  - e. All Permits required such as for crossings of State or County roads shall be obtained.
  - f. The Water District shall be given one week advance notice to arrange for inspection.
6. During construction, the Water District will provide inspections. Any work backfilled prior to inspection by the District will be uncovered and it will be rejected.
  7. Successful pressure testing provided by Owner, Developer, and supervised by District #3 employee, and successful bacteriological tests handled only by District #3 personnel must be completed prior to any main extension being put into service. Any additional testing of pressure or bacteriological will result in additional fees.
  8. Following completion and placing the new extension into service, the Owner shall convey ownership of the water main extension to the District after 1 year of completion and passing requirements by the form letter provided by the District.

## **SPECIAL NOTICE**

Regarding water main plan reviews, this is to advise that incomplete plans, or plans with errors (regardless of the magnitude) will be returned for revision before being submitted to our Board of Directors for approval. This applies especially to clearances between water mains and storm and sanitary sewers, including manholes and inlets. The horizontal separation shall be 10 feet and the vertical separation shall be 18 inches, as required by Missouri DNR. Where clearances appear to violate these criteria, the plans will be returned for revision. Also, all details, such as for ditch crossings, shall be clearly shown on the plans. It is to be clearly understood that review of plans is for general conformity only and in no way relieves the Engineers of his responsibility for correct plans.

Regarding construction, a pre-construction conference will be held for each new project, with the time and date set by the District Personnel. Attendance by the Contractor's field superintendent is MANDATORY! Construction may start only after this conference has been held, and the Owner/Engineer/Contractor has complied with all requirements as stated in the Item 5 of the Preface to the Main Extension Policy. It is to be understood that inspections of construction will be carried out by District #3 personnel; said inspections will be on a full-time basis. When work is performed in the absence of a District #3 Inspector, such work must be left open and visible until witnessed by a District #3 Inspector. Any work that is covered or backfilled prior to inspection shall be uncovered by the Contractor, at his expense, for inspection. Contractors shall schedule their work in accordance with the schedules of District #3 Inspectors. No work shall be performed on weekends or District #3 holidays. Inspections will NOT be scheduled for the convenience of Contractors. The Owner shall start construction within one (1) year from the notice approval. If construction has not started within a one (1) year period, the Owner will resubmit the plans and specifications for approval and repaying all applicable fees.

All of the above will be strictly enforced, and we urge all parties involved to comply with these requirements to avoid conflicts and delays.

Issued October 1, 2018

Terry Stotler  
District Manager  
Public Water Supply District #3

## **CHAPTER 8**

### **MAIN EXTENSION POLICY**

All Owners and Developers of properties within the District, which require water service from the District, shall acquire such water service in accord with the following procedures and policies:

#### **8.1 Plan Submittal Phase:**

**8.1.1** Owner or Developer shall submit to District Three (3) complete sets of Plans and Specifications, prepared and sealed by a Registered Professional Engineer of the State of Missouri, for the proposed water extension and distribution system. Submittals must be received at least 14 days prior to the meeting of the Board of Directors for approval by the board at any specific meeting. Said plans shall incorporate the following:

**8.1.1.a.** The District's specifications and construction standards as stated in Chapter 9.

**8.1.1.b.** The submitted set of plans shall have the approval of the Fire Marshall from the Fire District in the subject extension is located before they are transmitted to the Water District. This approval shall be in form of the Fire Marshall's signature on the subject plans.

**8.1.1.c.** The set of plans shall have a location map of the water extension showing the nearest major roadway system.

**8.1.1.d.** The submitted set of plans shall clearly identify all existing water mains and water main easements and such additional water mains and water main easements as are proposed for such development. Where any such plans identify a proposed dedication of right-of-way to the county or state, such plans shall clearly indicate the priority of existing water mains and water main easements over any such proposed dedication of right-of-way to the county or state.

**8.1.1.e.** The proposed water extension and distribution system shall include all water mains, valves, tapping sleeves and valves, fittings and fire hydrants as needed to provide domestic water service and to provide fire apparatus as required by the fire district to the area of proposed development. Additionally, the project shall include all service lines which must cross roadways to provide service as shown in Chapter 9, page 9.3.7 of these Rules and Regulations.

**8.1.1.f.** The plans shall include the plan and profiles of all sanitary and storm sewers and on the profiles, all water main crossings shall be shown to clearly illustrate that proper cover and clearances are provided and must be approved by the District Engineer.

**8.1.1.g.** All services lines must be surveyed and staked 6 feet to 10 feet from the property line that is opposite of the driveway. If the house on a lot is switched where the driveway is on the opposite side of the approved plans the developer/contractor will pay to install another service line 6 feet to 10 feet from the property line that is opposite the changed driveway.

**8.1.1.h.** Any previously approved plans over 1 year old must be resubmitted for approval.

**8.1.2** Form 10.1 and 10.3 shall be completed and submitted with the plans and specification and application fee shall be paid to the District with the submittal of the plans. The fee will be calculated from Form 10.1.

**8.1.3** The District Engineer shall review the submittal for conformance to District Standards, and, on developments of 15 lots or more or on developments of less than 15 lots where the District feels it necessary, the District Engineer will analyze the effect of the subject extension on the District's distribution system. The review by the District Engineer shall be for general conformance with the District's Standards only, and in no way releases the Developer, his engineer or contractor from producing a completed water system in accordance with District Standards. Any errors, omissions or deviations from the District's Standards discovered prior to, during or after construction shall be promptly corrected by the Developer at no expense to the District. Upon completion of the review by the District Engineer, he will forward his review to the Developer and his Engineer.

If there are changes required by the District's Engineer, the Owner or Developer shall have his Engineer make modifications noted and resubmit three (3) sets for final conformity to District's Standards. If a resubmittal is required because of failure to make the modifications noted, the Owner or Developer shall pay for the additional review time by the District's Engineer at the rate stated in Form 10.1.

**8.1.4** Upon approval of the proposed water distribution system by the District's Engineer, the plans will be presented to the District Board of Directors for their approval.

**8.1.5** In order to be approved to install the water mains, valves, fire hydrants and other appurtenances including service taps in the District the contractor must be determined to be qualified to perform such work. The District will maintain a listing of Qualified Contractors for any water system work to be conducted in the District. In order to be placed on the Qualified Contractors list, each contractor must meet the following conditions:

(1) Furnish and maintain a Performance Bond with a minimum of \$5,000.00 (five thousand dollars) for service lines and any work \$5,000.00 and under. A larger bond will be required for work exceeding \$5,000.00 to be determined by District #3 or its' engineers and shall be valid for one year.

(2) Furnish certificate of insurance including XCU coverage. The minimum limits of general liability insurance required by District #3 are \$1,000,000 each occurrence and \$2,000,000 general aggregate. The certificate of insurance must also have umbrella liability coverage of \$1,000,000 and must name Public Water Supply District No. 3 as an "Additional Insured". Contractor must provide a certificate of insurance for Worker's Compensation Insurance.

(3) Furnish to the District a completed copy of a Statement of Qualifications (copy attached).

The District will review said Statement of Qualifications and determine those Contractors to be placed on the Qualified Contractors list. In all cases the decision of the District regarding those to be placed on this list shall be final and conclusive.

**STATEMENT OF QUALIFICATIONS**

Date Submitted \_\_\_\_\_

Name of Contractor \_\_\_\_\_

Address \_\_\_\_\_

\_\_\_\_\_

Telephone Number \_\_\_\_\_

Type of Company, i.e. Corporation,  
Partnership, Single Ownership \_\_\_\_\_

No. of Years in business \_\_\_\_\_

Name and Address of Bank \_\_\_\_\_

\_\_\_\_\_

\_\_\_\_\_

Name and Address of Insurance Co. \_\_\_\_\_

\_\_\_\_\_

\_\_\_\_\_

Name and Address of Bonding Co. \_\_\_\_\_

\_\_\_\_\_

\_\_\_\_\_

Attached is a listing of references for whom similar work has been performed during the last five (5) years. The listing shall include the name of the party for whom the work was performed, along with their address, phone number and a person to contact who is familiar with the work performed, the name of the work and the dollar value of the contract. For contractors that have performed extensive work in District #3, this requirement may be waived at the sole discretion of the District.



## **8.2 Construction Phase:**

**8.2.1** After the approval of the plan submittal phase the Owner or Developer shall acquire and submit to the District any highway or county roadway permits and all easements which are necessary for construction of the water main extension. The District will have the easements recorded with the proper agencies for the Owner and Developer. Easements shall conform with the Standard Easement Form 10.6.

Upon specific request of the owner or developer the District may accept a copy of the proposed record plat depicting the required easements in lieu of the Standard Easement Form 10.6. Such record plat must be signed by the current owner or owners of the property involved and signatures shall be notarized. The plat shall be submitted in printed form and on a USB drive in AutoCAD and DXF format for use by the district.

**8.2.2** Prior to the start of construction, the Developer shall have all of the grading in the vicinity of water mains or appurtenances completed to within 12 inches, plus or minus, from the finished grade and shall have the proposed water line staked out in the field by his Engineer or Surveyor. This stake out shall consist of placing stakes on line or on a fixed offset for all pipe, tapping sleeves and valves, bends, tees, valves, fire hydrants and all other water main appurtenances. Where road crossings of service lines of individual service liens are to be installed, the front property corners of the properties involved shall be staked. The stakes shall extend at least 12" above the ground, be 1" x 2" or larger, and be clearly labeled to indicate the water system components to be placed at that location. The stakes shall also be clearly labeled as to the "cut" (depth of cover) of the water system component relative to the existing ground level such that the finished cover over the water system component will be 3' - 6", or, with the approval of the District #3 Inspector, deeper if necessary to clear obstructions, but in no case deeper than 6' - 0". If the pipe is to have more than or less of 3'6" of cover (based on finished grade) this shall be clearly shown on the Plans. Along straight runs of pipe, the stakes shall be set at every other lot line not exceeding 200 feet. One set of plans, with the stake locations clearly shown thereon, shall be submitted to the District Engineer and the staking shall be inspected and approved by the District prior to the start of construction. Stakes must remain in place until the installation involved is completed. In the event the stakes are disturbed or removed prior to the water main installation, it is the responsibility of the Developer to have these stakes replaced at no cost to the district. Also if the water main or component is not installed in its intended location, or at its intended depth, for any reason, it shall be the responsibility of the Developer to have the water main or component adjusted to the correct line and grade at no cost to the District. When this is complete, all road crossings (main and service lines) can be installed and inspected by District #3 personnel. All other work to be completed after pavement has been installed.

**8.2.3** The Construction inspection Fee shall be calculated as shown on Form 10.2 herein and paid by the Owner or Developer prior to construction. After payment of the

construction inspection fee, the Owner or Developer shall notify the district one (1) week prior to construction of the water main extension. The Owner shall start construction within one (1) year from the notice of approval. If construction has not started within a one (1) year period, the Owner shall resubmit the plans and specifications for approval and replaying all applicable fees.

**8.2.4** Upon completion of the construction of the water main extension, the water main extension shall undergo testing under the supervision of District personnel or the District's Engineer. All costs for construction supervision, one pressure test of the water lines and 3- bac-T tests are included in the construction permit fee as described in 10.2 stated herein. Additional tests will cost \$100.00 per pressure test and \$125.00 per Bac-T test. As a part of the final testing, the Contractor shall operate all valves and fire hydrants in the presence of a representative of District #3 to ensure property operability and to ensure that all valves are left open. Also as a part of the final testing, all valves, fire hydrants, meter boxes, T posts for service line road crossings shall be observed to determine that they are at the proper location and grade and W's cut in curb on both sides of street. Test race wire under supervision of District #3 Inspector. Make sure vertical cut is made in the top of valve boxes for trace wire. Any found not in conformance shall be immediately corrected by the Contractor.

**8.2.5** If testing is satisfactory to the District and the water main extension is acceptable to the District, the Owner or Developer shall furnish to the district legal title to the water main extension, in the form of a Quit Claim Deed (form 10.15) and copies of all recorded subdivision plats not furnished prior to construction. After said conveyance, the water main extension shall be deemed a part of the District's facilities. Prior to accepting the Quit Claim Deed, the District may require copies of lien waivers from those who perform work or labor upon or furnish any materials for the main extension.

**8.2.6** Owner or Developer warrants the water main extension for one year commencing on the date of completion. Owner or Developer shall immediately upon notice by the District replace and/or repair the extension during the one year period, or district shall so replace and/or repair at Owner or Developer cost and expense unless the replacement and/or repair is necessitated because of District's negligence or the negligence of third parties.

By the form letter provided by the district, attached, following completion and placing the new extension into service, the Owner shall convey ownership of the water main extension to the district after 1 year of completion.

*(print on letterhead)*

**DOCUMENT OF VALUE OF DONATED PROPERTY**

**Developer/Owner completes:**

From: \_\_\_\_\_ (Name)

Address: \_\_\_\_\_  
\_\_\_\_\_

Sub/Dev: \_\_\_\_\_ Water Distribution System

\_\_\_\_\_ (name) donated the above named water distribution system to Public Water Supply District #3 of Jefferson County, Missouri and guarantees to pay for the repair of said main for a period of one year (per district Rules and Regulations 8.2.6) from this date, \_\_\_\_\_, 2018.

The dollar value of the main extension is: \$ \_\_\_\_\_ and/or attached the invoice for the installation.

\_\_\_\_\_  
Signature

\_\_\_\_\_  
Title

\_\_\_\_\_  
Date

## **CHAPTER 9 – SPECIFICATIONS/FOR PLANS AND BLUEPRINTS**

**9.1** Specifications for installations acceptable to the district and required on plans or blue prints are set forth and illustrated in the attached index as follows:

**9.2** Written Specifications Index

- 9.2.1** Pipe Requirements
- 9.2.2** Pipe and Fittings
- 9.2.3** Gate Valves
- 9.2.4** Valve Boxes
- 9.2.5** Tapping Sleeves and Valves
- 9.2.6** Fire Hydrants
- 9.2.7** Flush Hydrants
- 9.2.8** Grade Restrictions + or – 1'
- 9.2.9** Trace Wires
- 9.2.10** Deleted 11/14/16
- 9.2.11** Separation of Water Mains, Sanitary Sewers & Storm Sewer
- 9.2.12** Trench Excavation & Backfilling
- 9.2.13** Water Main Protection
- 9.2.14** Concrete for Thrust Blocking
- 9.2.15** Disinfection
- 9.2.16** Pressure Testing
- 9.2.17** Deleted 11/14/16
- 9.2.18** Water Services and System Locations
- 9.2.19** Air Release Valves
- 9.2.20** Bedding and Backfill for Copper Tubing and Blue Poly
- 9.2.21** Meters and Service Lines
- 9.2.22** Main Line Pressure Reducing Valves

**9.3** Plans Specifications Index

- 9.3.1** Fire Hydrant Detail (Use current AWWA standards)
- 9.3.2** Valve Support Block (Use current AWWA standards)
- 9.3.3** Horizontal Bends (Use current AWWA standards)
- 9.3.4** Vertical Bends (Use current AWWA standards)
- 9.3.5** Dimensions for Vertical Bends (Use current AWWA standards)
- 9.3.6** Typical 1" & Smaller Meter Service
- 9.3.7** Typical Section for Service Line  
(New Construction for Road Crossings)
- 9.3.8** Typical Trench Section (Use current AWWA standards)
- 9.3.9** Typical Air Release Valve
- 9.3.10** Typical Creek or Ditch Crossing (Use current AWWA standards)  
For 6" or 8" Pipe

## **9.2 WRITTEN SPECIFICATIONS:**

### **9.2.1 Pipe Requirements:**

In general the working pressure in the District will be considered to be 200 PSI maximum with a 65 PSI minimum. However, there are areas where the working pressure is higher than 200 PSI. For any new developments, the developer or his Engineer shall contact the District Engineer to determine whether or not the proposed water main extension is in a high pressure zone or low pressure zone. All piping shall be ductile iron pipe or PVC pipe conforming to AWWA C-900 as specified in Paragraph 9.2.2 of these Rules and Regulations. The test pressure for both pressure zones shall be 300 PSI. In addition, if the area is determined to be in a high pressure zone or low pressure zone by the District Engineer, main line pressure reducing valves in District #3 approved underground enclosures as specified in Section 9.2.2 of these Rules and Regulations may be required. Where low pressure zone exists high side looping or looping will be required per District #3 Engineer specs. Where pipe is to be located under pavement and islands exceed 50 feet, all such pipe under the pavement and islands shall be ductile iron pipe.

### **9.2.2 Pipe and Fittings:**

PVC pipe for all zones shall conform to AWWA C-900 and be pressure class 200 with a dimension ratio (SDR) of 14. Gaskets shall conform to ASTM D-1869.

Ductile iron pipe shall conform to AWWA C-151 and have PC350 wall thickness. The pipe shall be cement lined and seal coated in accordance with AWWA C-104. The joints shall be push on type with rubber gaskets conforming to AWWA C-111. Where restraint is deemed necessary, field locks will be required, or mechanical lug restraint gland packs conforming to current specs.

For all water main crossings of State and County roadways, the pipe shall be ductile iron. If casing pipes are required by the State or the County, the details shall be approved by the State or County and the District Engineer, and shall include appropriate spacers for the water mains inside the casing pipe.

All fittings shall be ductile iron, Class 350, conforming to AWWA C-153. The fittings shall have mechanical joints conforming to AWWA C-111 and be cement lined and seal coated in accordance with AWWA C-104. All bolts to be sprayed with "Bitumastic Super Service Black" as manufactured by Kop-Coat Gasoline Supply, or Approved equal.

All ductile iron pipe and fittings shall be installed in accordance with AWWA C-600. PVC pipe shall be installed in accordance with AWWA Manual No. 23. In the event there is any conflict between these Rules and Regulations and AWWA C-600 or AWWA Manual No. 23, the provisions of these Rules and Regulations shall govern.

### **9.2.3 Gate Valves:**

All gate valves shall be ductile iron or cast iron, resilient wedge valves, with non-rising stems, operating nuts, mechanical joints and epoxy coated bodies and be manufactured in accordance with AWWA Standard C-509. The wall thicknesses for ductile iron valves shall meet or exceed AWWA Standard C-153. The valves shall be designed to withstand a working pressure of 250 PSI on either side of the valve. The valves shall be US Pipe Metroseal 250, Tyler Class 250, Mueller A-2360, AFC 2500 Series, or approved equal.

For three way connections, all three gate valves shall be provided. For four way connections all four gate valves shall be provided. The maximum spacing between valves shall be 1,000 feet.

The valves shall open counterclockwise and have the maker's initials, pressure rating, and year in which manufactured cast on the body. Where valves are set at a depth that leaves the operating nut more than four (4) feet below the proposed grade, an extension stem shall be furnished to bring the operating nut to within two (2) feet of the proposed grade.

### **9.2.4 Valve Boxes:**

All gate valves, including tapping valves shall be provided with buffalo type valve boxes, Type 562-S or 564-S, or approved equal, and shall be furnished with a Valve Box Adapter rubber boot style only or approval equal. The tops of the valve boxes shall be designed with grooves to accommodate a valve box adjusting tool as provided in the tops of the above referenced Tyler valve boxes. The valve boxes shall be complete with extension pieces where necessary and the top of the boxes shall be flush with the finished grade or pavement surface. A vertical slot shall be cut in top of valve box to accommodate trace wire.

### **9.2.5 Tapping Sleeves and Valves:**

All tapping sleeves shall be stainless steel with stainless steel flanges. For areas where the working pressure equals or exceeds 200 PSI, tapping sleeves shall be Power-Seal No. 3490 AS with Class 125 ANSI B-16.1 flanges on the outlets. As an option, if approved by District #3, Mechanical Joints. For areas where the working pressure is less than 200 PSI, the tapping sleeves may be Power Seal No. 3490 AS, Smith Blair 665.

Tapping valves shall be designed for leak tight attachment to the tapping sleeve and tapping machine and shall otherwise conform to Section "9.2.3 Gate Valves" of these Rules and Regulations.

### **9.2.6 Fire Hydrants:**

Fires hydrants shall be installed as shown on Page 9.3.1 and shall have a 5-1/4" valve opening, one 4-1/2" steamer nozzle and two 2-1/2" hose nozzles and a 6" mechanical joint shoe. The fire hydrants shall be Mueller Figure A-423 or American Darling No. B-84-B. Each fire hydrant shall have approved valve front section 9.2.3 6" auxiliary valve and valve box from 9.2.4 installed with it. Fire hydrants as delivered to the site shall be coated with a black bituminous coating for the portion to be underground and a primer and yellow finish coat for the portions to be exposed. The types of paint and coating shall be as recommended by the fire hydrant manufacturer. All hydrants shall receive a final paint coat in the field. Exposed barrels shall be chrome yellow and all tops shall be red if connected to a six inch diameter or small water main, orange if connected to an eight inch main, green if connected to a twelve inch main, and light blue if connected to mains larger than twelve inches. All hydrant cap threads shall be field-lubricated with approved food-grade grease. The hydrants shall have a minimum "bury" of four (4) feet unless the depth of the main requires a deeper "bury".

For fire hydrant assemblies, swivel joint or anchor lock fittings as manufactured by Tyler or Clow, or approved equal will be used, provided that such fittings provide complete restraint of unbalanced thrusts and provide the same degree of flexibility at the joints as standard mechanical joints. Any hydrant lead longer than 2 feet can be an anchor lock fitting or restrained ductile iron pipe using mega lugs or grip rings. No PVC pipe shall be allowed on any part of a hydrant lead. Thrust blocking behind the tee and the fire hydrant will still be required as shown on the drawing on Page 9.3.1 of these Rules and Regulations. Additionally, where grade changes are needed between the mains and the fire hydrants, ductile iron Gradelok fittings as supplied by Assured Flow Sales, Inc., approved equal may be used, subject to approval by the District Personnel on a case by case basis.

Under no circumstances will any type of locking joints (except as specified above for fire hydrants) be permitted in place of concrete thrust blocking or tie rodding.

### **9.2.7 Flush Hydrants:**

Where there is a need for a flush hydrant, there shall be installed a fire hydrant as specific above in 9.2.6, compete with auxiliary valve and valve box. No smaller flush hydrants will be allowed.

### **9.2.8 Grade Restriction:**

In general the grade or slopes where new water mains are to be installed shall not exceed 10%. Where grades are in excess of 10% but not greater than 25% class 52 Ductile Iron pipe or awwa C-900 DR-14 will be used, each joint of pipe shall be restrained by means of external spigot and hub threaded rod type restrainer to be coated with bitumastic spray.

### **9.2.9 Trace Wires:**

For PVC, for ductile iron water mains and for service line road crossings, a single No. 12 solid copper wire, THHN or THWN, gasoline and oil resistant, and shall be placed in the pipe trench. The wire shall be taped to the top of pipe and service lines and shall be carefully placed and brought up to ground elevation at the end of each water main segment in a top section of a water valve box or other approved container. Where valves are installed, the trace wires shall be brought up the outside of the valve box with a small loop inserted into the valve box. The service line wire should be brought up inside the meter tile with enough to extend out of meter tile and should never be connected to the main line wire.

### **9.2.11 Separation of Water Mains, Sanitary Sewers and Storm Sewers:**

Water mains shall be laid at least 10 feet horizontally from any existing or proposed sanitary or storm sewer. The distance shall be measured edge to edge. In cases where it is not practical to maintain a ten foot separation, deviations may be made on a case-by-case basis, if supported by data from the design engineer. Such deviation may allow installation of the water main closer to a sewer, provided that the water main is laid in the separate trench or on an undisturbed earth shelf located on one side of the sewer and in either case, at such elevation that the bottom of the water main is at least 18 inches above the top of the sewer.

Water mains crossing sewers shall be laid to provide a minimum vertical clear distance of 18 inches between the outside of the water main and the outside of the sewer. This shall be the case where the water main is either above or below the sewer. At crossings, the full length of water pipe shall be located so both joints will be as far from the sewer as possible.

There shall be at least a 10 foot horizontal separation between water mains and sanitary sewer force mains. There shall be an 18 inch vertical separation at crossings as required above for gravity sewers.

### **9.2.12 Trench Excavation and Backfilling:**

Trenches for water mains shall have a minimum width of the pipe O.D. plus 12 inches, and a maximum width of the pipe O.D. plus 24 inches. The trench depth shall be such to provide 6 inches of granular bedding beneath the pipe and 8" over pipe. The finished cover over water mains shall be 42". Where additional depth is necessary to clear other utilities or obstructions, the district may grant permission to allow such additional depth, but in no case shall the cover over any water main exceed 6'-0".

Where new water mains are being installed, the same limits as to minimum and maximum cover shall apply to existing water mains as specified above for new water mains. Reference is made to Section 6.10 of these Rules and Regulations.



Granular material for backfill shall be well graded 3/4" minus crushed rock and screenings. In all cases, the granular fill shall be placed 6" below the bottom of the pipe to 8" above the top of the pipe. For areas under roadways, driveways and parking areas, the balance of the backfill shall be made with compacted granular backfill. In other areas the balance of backfill may be excavated earth, free of large stones, frozen material, vegetation and debris.

Trench bottoms shall be constructed with granular backfill, well compacted in 6" layers, to provide a firm, stable and uniform support for the full length of the pipe. Whenever an unstable subgrade condition is encountered, additional trench depth shall be excavated and refilled with compacted granular backfill. When the pipe is placed in the trench, bell holds shall be provided if needed to allow full contact of the pipe with the granular fill bed. Backfill to the center line of the pipe shall be carefully placed with the backfill material worked along the sides of the pipe to ensure that the space beneath the pipe is completely filled. The balance of the granular backfill shall be placed in compacted 6 inch layers. Compaction beneath and above the pipe may be done with a backhoe bucket.

Where water mains cross "major" creeks, all piping shall be ductile iron. Proper fittings shall be provided and all hubs shall have field locks. All fittings shall have mega lug or other approved restrainer glands and concrete encasement may be required in large crossings. This will be determined by District #3 Engineers.

In areas where earth backfill is permitted above the granular backfill, the backfill may be mounded up to allow for settlement. However where the work is in lawn areas, the earth backfill shall be compacted in 8 inch layers to the finished grade to prevent future settlement.

Where water mains are installed in off-site easements, the disturbed areas shall be seeded, mulched and fertilized to restore the areas to their original condition or better. In some situation sod may be required.

Seed shall be broadcast either by hand or by approved sowing equipment at a rate which will provide fifty (50) pounds of the specified seed mixture per acre. The seed shall be uniformly distributed over the areas to be seeded. The seed shall be fescue.

The Contractor shall be responsible for the proper care of seeded areas during the period when the grass is becoming established. Any area to be seeded which does not produce a suitable stand of grass shall be reseeded as directed by the District Engineer.

**9.2.13 Water Main Protection:**

Water main materials shall be installed as stated in Section 9.2.2 of these written Specifications. Additionally, the water main shall be carefully stored on the site and carefully lowered into the trench during installation. Under no circumstances shall materials be dropped or dumped into the trench. At the end of each working day the end, or ends of all pipe shall be sealed by means of a watertight plug to seal the pipe opening. Pipe deemed to be damaged or dirty pipe will not be used.

**9.2.14 Concrete for Thrust Blocking:**

Concrete for thrust blocking shall be ready mix concrete, composed of portland cement, sand and gravel with not more than six (6) gallons of water per sack of cement. The concrete shall be a 5-1/2 sack mix with 28 day minimum compressive strength of 3,000 PSI.

**9.2.15 Disinfection:**

All pipes shall be disinfected in accordance with AWWA C-601 prior to being placed into service in the following manner: Disinfection shall be by the tablet method. Hypochlorite tablets (HTH) shall be attached to the pipe during installation with two tablets per 20 foot length. Following installation, the main shall be filled with water at a velocity not to exceed one (1) foot per second. The water shall remain in the pipe for 24 hours prior to flushing.

After flushing the chlorine residual shall be tested and shall be between 0.5 – 1.5 mg/l. Following disinfection, flushing and pressure testing, samples shall be taken on two consecutive days for bacteriological testing. If the same are acceptable, the mains may be placed in service. If the samples are not acceptable, the mains shall be re-flushed and/or re-chlorinated until the bacteriological tests meet the requirements stated above. This will be done at the contractors expense.

**9.2.16 Pressure Testing:**

All mains shall be tested to 300 PSI at the lowest point for a period of 1 hour. Pipe shall be filled slowly with water with 1" taps made at any high points needed to release air. The allowable pressure drop during the 1 hour test shall be 0 PSI.

**9.2.17 Fittings and Pipe Deflections**

**9.2.18 Water Services and System Locations:**

For all new water main installations, there will be no water main installed until the streets are completed. This practice is to insure that our utility will be in the correct location. Fire hydrants shall be located five (5) feet from the water main, or three (3) feet from the edge of the streets.

There shall be a single service line for each property to be served. Where road crossings are required for water services, the installation shall be as shown on Page

9.3.7. No part of any road crossing shall be under any driveway including saddle, copper pipe, poly pipe, etc.

All service lines shall be installed in a 4" diameter Schedule 35 or Class 200 PVC pipe sleeve and a W be cut in both curbs. Road crossing service line pipe encasements may be installed prior to street completion or the contractor may bore and install them after the streets are completed when the main installed. If at time of installation the sleeve pipe is not at proper depth, a new sleeve will be installed at owner/developer's expense. When the services are then to be installed, pipe is to be sleeved from within 1' of the corporation stop with a furnco 4" cap or acceptable, similar product on the end with a hole cut into cap to accommodate the ¾" or 1" service line and locate wire through it and on the non-main side of the street. The sleeve will continue to meter tile. The use of the furnco couplers, 45° and 22° bends with NO GLUE PERIOD is acceptable. The pipe should be white or blue in color only, no green sewer pipe. All shall be bedded in accordance to procedures provided in 9.2.12 6" under sleeve pipe and 8" over sleeve pipe with acceptable stone copper tubing will only be used when deemed necessary. Blue ADS Poly Flex 4710, AWWA C-901 SDR-9 ASTM D-2737 CTS pipe is to be used for all services 2" or less with brass fittings and stiffener inserts. The meter setters will be AY McDonald Brand NL ¾" is 721-215QFQQ33 and 1" is 721-415QFQQ44 with Q cts compression for inlets and outlets cartridge style dual check valves and ball type angle valves with swivel nut for meter set. All services main side or road crossing will be done in accordance with procedures defined above. A 20" piece of ½" hard copper tubing, or ½" ground rod will be used to stabilize meter setter in area provided and the locate wire will be brought up in meter tile enough to extend out of tile. In situations where a new service is to be installed as a road crossing and the pavement is existing a 2" poly pipe or 2" pvc pipe as defined above may be used for the road bore 2" pipe will be used from corp stop to meter tile as defined above.

It is recognized that there may be situations where the above locations are not possible or practical. In such cases, the Developer's engineer or contractor shall make a written request for a deviation from the location policy as defined above. The request shall state clearly the reasons that the location policy is not possible and where the facilities are to be located. In such cases, the request shall be reviewed by the Manager of the District and the District Engineer. The decision of the Manager in such cases shall be final and conclusive.

Water main that is to go through the cul de sacs with the developer providing clean dirt in the common ground area in the center of the cul de sacs. NO structure over water main in cul de sacs.

**Section 9.2.19 Air Release Valves:**

Where there are pronounced high spots in water mains and no fire hydrants are located at said high spots, an air release valve as detailed on Plan Specification

Drawing 9.3.9 shall be installed. The purpose of this facility is to allow air to escape during the water main filling process and the curb stop will then be shut off. These facilities are to be permanent structures for future use by the District #3 as the needs arise. The determination of the need for air release valves and locations of the same shall be made by the District Engineer based on topographic maps and/or profiles provided with the plans submitted.

#### **9.2.21 Meters:**

Before any water meter service is installed, the payment of \$750.00 per new 3/4" meter connection, \$1,500.00 per new 1" connection, \$5,000.00 per new 2" meter connection will be paid for each unit (each home, trailer pad, apartment, condominium, ect.). Larger connections shall be calculated individually. A water user agreement will be signed and completed for each meter service.

The meters for the basic 5/8 x 3/4 inch services shall be Sensus I-Pearl meters installed and equipped with ECR encoder registers and meter transceiver units (MXU) to allow the meter to be read automatically. The District will allow contractors who have the \$5,000.00 Performance Bond and the required insurance certificate on file with the District to make the tap and meter pit installation, as shown on Page 9.3.6, excluding the meter. The actual meter with encoded register will be installed by the District, upon satisfactory approval by the District's Inspectors, whereby the contractor may then purchase water for construction purposes. A Final inspection of the meter service will be performed by the District before the electronic package is installed and before the service may be activated. This inspection shall coincide with closing and no deposits will be accepted from the customer until successful final inspection. The meters and the transceiver units must be purchased from the supplier (Core & Main stocks the MXU's & meters).

#### **9.2.22 Main Line Pressure Reducing Valves:**

Where a main line pressure reducing valve is required, it shall consist of an underground packaged pressure reducing station as manufactured by Engineered Fluid, Inc., Centralia, Illinois, or approval equal. The primary pressure reducing valve shall be sized as required by the District Engineer. The pipeline on each side of the pressure reducing station shall have a gate valve installed within 10 feet of the pressure reducing station such that the entire pressure reducing station can be shut down without taking any customers out of service.

The station shall be an underground steel capsule, 7'-0" outside diameter with an inside height of 6'-6". The station shall have a rectangular access hatch 30" x 36" with a Bilco Model MS-50 roof scuttle made of 11 gauge aluminum. The scuttle cover shall have 1" of fiberglass insulation protected by an 18 gauge aluminum liner. The entry lock on the access hatch shall be the pin tumbler, dead bolt type with a safety release, all as shown on Bilco Drawing 6184. Two keys shall be provided.

The top and bottom plates shall be lap welded to the capsule and the joints of all steel components shall be lap welded. The capsule shall be reinforced by channels and angles and be provided with lifting plates. The station shall be installed and bolted to an 8" thick reinforced concrete pad. The top of the access hatch shall be 11" above finished grade.

An aluminum access ladder shall be provided which meets UL and OSHA qualifications under Type I, Heavy duty Specifications. The ladder shall be bolted into place and be removable to allow equipment maintenance. The capsule shall be provided with an 18" diameter, 8" deep sump. The capsule working area shall be covered with a rigid, neoprene floor mat. Pipe supports shall be provided inside the capsule as needed for the support of the equipment. No lighting or other electrical equipment will be required inside the capsule.

All surfaces of the entire structure shall be sandblasted (SSPC – SP6) and coated with Tnemec Series 66 Hi-Build Epoxyline, applied in two applications to a total dry film thickness of 8.0 mils. Two 17 pound packaged magnesium anodes shall be provided, buried and attached by heavy copper wire to lugs provided for that purpose.

The main line pipeline through the capsule shall have a normally closed isolation valve and a compression coupling of flanged coupling adapter to allow removal of the isolation valve. The primary pressure reducing valve shall be located in a bypass loop, the same size as the main line. The loop shall contain, in addition to the primary pressure reducing valve, two isolation valves and a compression coupling or flanged coupling adapter to allow removal of the equipment. All isolation valves shall be rated at 250 PSI working pressure. There shall also be provided a 3" loop with the secondary pressure reducing valve (3"), two 3" isolation valves and a coupling for the removal of equipment. All piping shall be schedule 40 steel with flanged ends except that the 3" piping and fittings shall be stainless steel. Where the pipes pass through the capsule wall, they shall be fully welded along with the circumference on both sides of the capsule wall.

A pressure gauge shall be provided in the piping on each side of the pressure reducing valves. The gauges shall have 4 ½" diameter clear faces. The gauge on the inlet side shall have a range of 0 – 200 PSI and the gauge on the outlet side shall have a range of 0 – 100 PSI.

The primary pressure reducing valve shall be a Cla-Val Model 690G-01ABC or approved equal. The secondary pressure reducing valve shall be a Cla-Val Model 90G-01ABCS or approved equal. The valves shall both have all stainless steel trim.

The supplier of the pressure reducing station shall provide 2 bound copies of O & M Manuals to the District, and shall provide one full day at the job site for start-up and training.

In the event a pressure reducing station is proposed, other than as manufactured by Engineered Fluid, Inc., plans of the station showing all structural and piping details shall be submitted along with the water main extensions. Also included shall be details of the PRV's to

be furnished. These plans must bear the seal and signature of a Missouri Registered Professional Engineer. Approval of both the plans for the water main extension and the PRV Station must be granted by the District Engineer before the project will be submitted to the Board of Directors for approval. If requested, structural calculations shall be provided in addition to the drawings of the PRV station. Deviations to the station as specified will only be allowed at the sole discretion of the District Engineer. Care must be exercised that the station is designed to allow easy access to the main PRV and piping and that the top hatch is located such that the main PRV can be easily removed. The contract shall provide the services of one full day by a representative of the PRV valve manufacturer for startup and training.

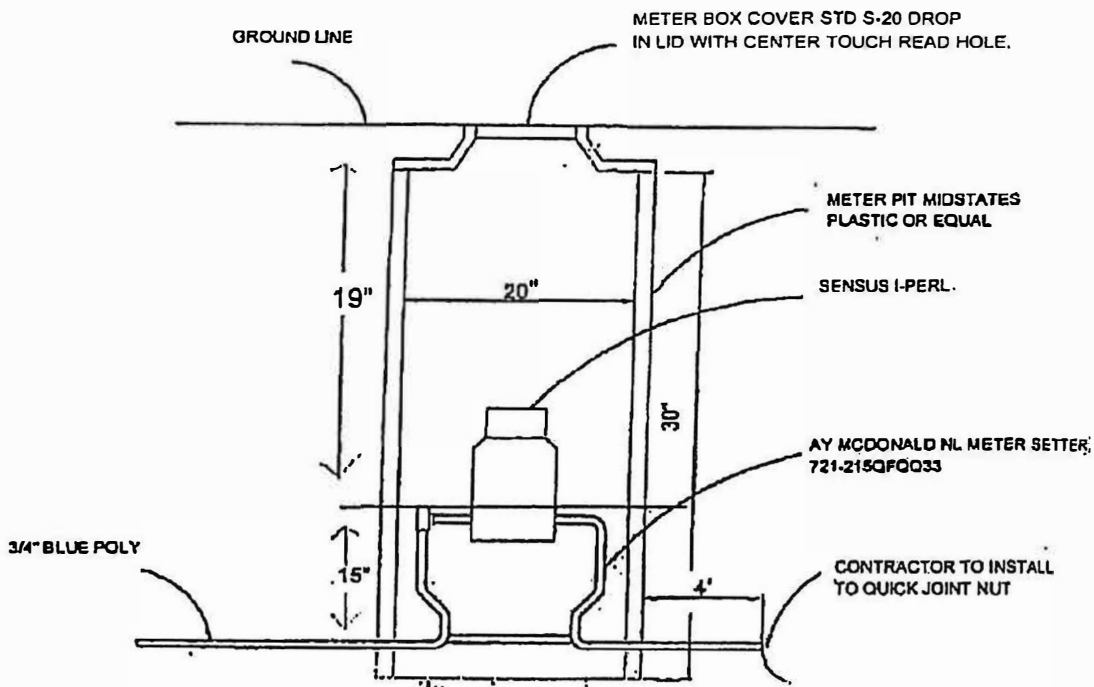

A.Y. MCDONALD  
BRONZE SERVICE CLAMP

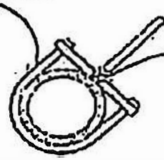

CORPORATION STOP MUELLER  
B25008 OR FORD F10003Q (3/4")  
OR AY MCDONALD

**TYPICAL 3/4"  
METER SERVICE**

NOT TO SCALE

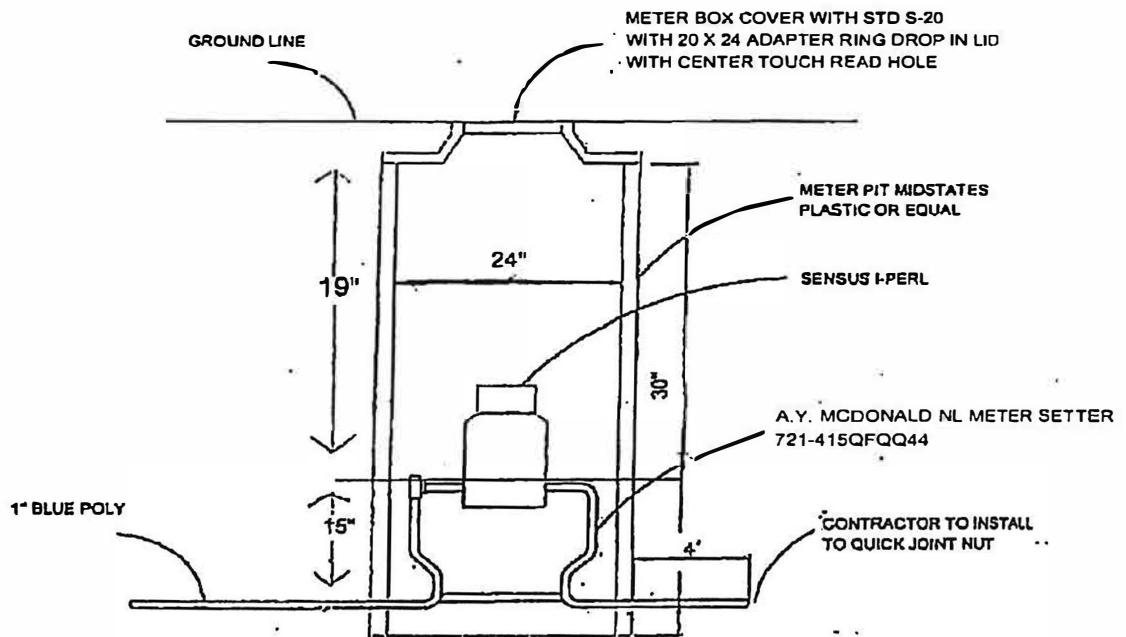

A.Y. MCDONALD BRONZE SERVICE CLAMP

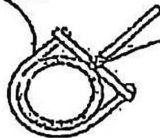

CORPORATION STOP F10004Q(1") OR A.Y. MCDONALD

**TYPICAL 1" METER SERVICE**

NOT TO SCALE



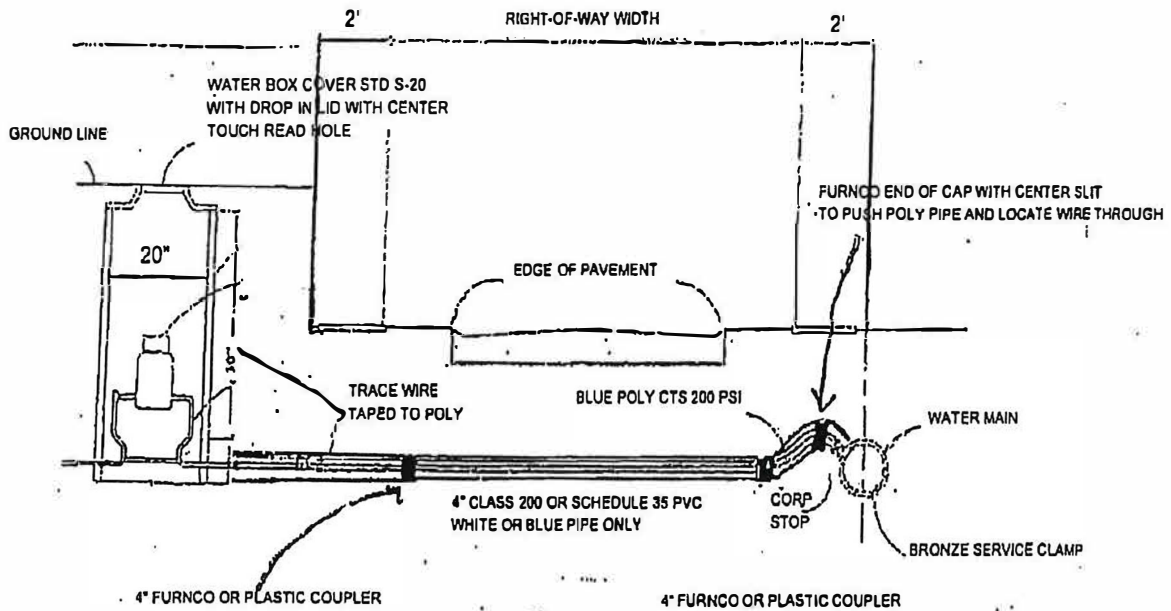

**NOTES:**

1. SIZE OF SERVICE LINE FOR ROAD CROSSING SHALL BE 3/4" OR 1" TO SINGLE CUSTOMER
2. CONTRACTOR TO INSTALL ALL ROAD CROSSINGS PER DIRECTION OF THE WATER DISTRICT
3. SERVICE LINE PIPE SHALL BE SLEEVED FROM 1' FROM CORP STOP TO THE METER
4. USE OF FURNCO COUPLERS AND PLASTIC COUPLERS, 22-45 DEGREE BENDS WITH NO GLUE
5. SERVICE LINE WIRE SHALL NOT BE CONNECTED TO MAIN LINE WIRE

**TYPICAL SECTION FOR**  
**SERVICE LINE**  
 (New Construction For Road Crossing)  
 NOT TO SCALE

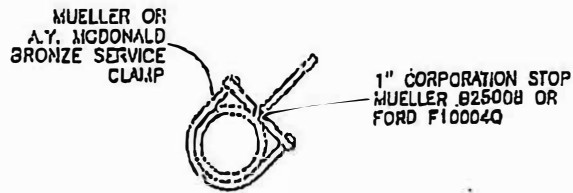
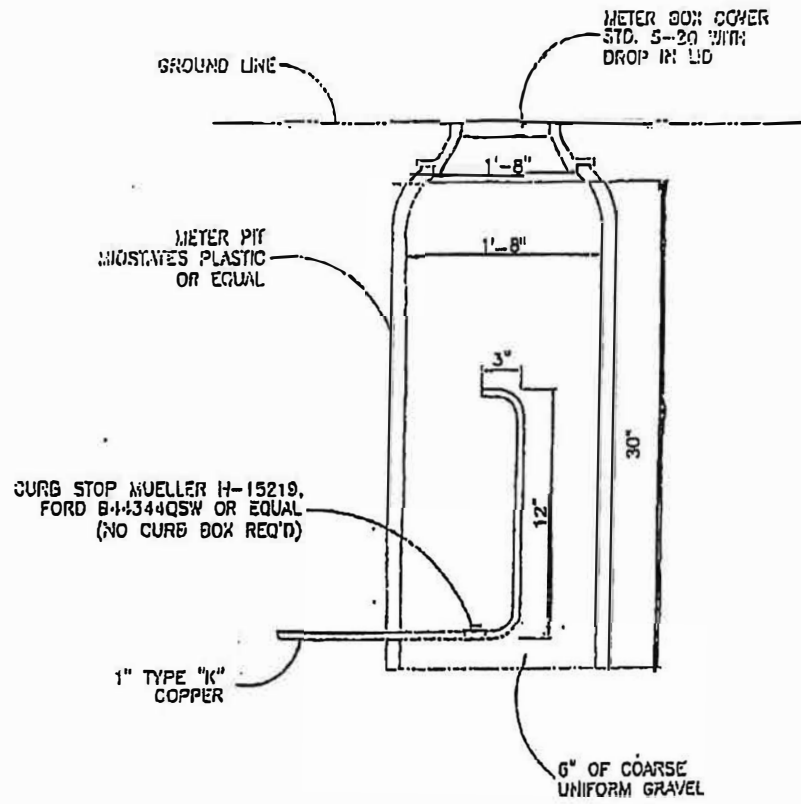

TYPICAL AIR RELEASE  
VALVE

NOT TO SCALE

## **FORMS**

Forms used by the District for developments are attached and indexed as follows:

- 10.1 Subdivision Review Fee form
- 10.2 Construction Inspection Fee Form
- 10.3 Developmental Information Form
- 10.4 Annual Performance Bond with Surety Form
- 10.6 Water Main Easement Forms
- 10.12 Subdivision Plat Language (Required on Plats)

10.1

***PUBLIC WATER SUPPLY DISTRICT #3***

**NEW DEVELOPMENT REVIEW FEE FORM**

PROJECT NAME: \_\_\_\_\_

**COST TO REVIEW**

Base Cost \$400.00

Review by Engineers:

\$.35/feet of water line x pipe factor\*

\*Pipe Factor: 6" = 1.0

8" = 1.25

10" = 1.5

12" = 1.75

16" = 2.5

>16" determined by District Engineer \$\_\_\_\_\_

Total \$\_\_\_\_\_

This form must be completed and submitted with Review Fee at the pre-construction meeting.

Date Paid \_\_\_\_\_

***PUBLIC WATER SUPPLY DISTRICT #3***

**COST TO REVIEW PLANS AFTER SECOND SUBMITTAL**

	<u>Hourly Rate</u>
District Engineer	\$100.00
Project Engineer	\$65.00
Outside Consultant, if required	At Cost

There will be a minimum of a two (2) hour charge for reviewing the resubmitted plans after second submittal.

**PUBLIC WATER SUPPLY DISTRICT #3**

**CONSTRUCTION INSPECTION FEE FORM**

PROJECT NAME: \_\_\_\_\_

**COST TO INSPECT**

Base Cost (includes one pressure test)\* \$400.00

Inspection Fee:

\$.50/feet of water line x pipe factor\*

\*Pipe Factor: 6" = 1.0

8" = 1.25

10" = 1.5

12" = 1.75

16" = 2.5

>16" determined by District Engineer \$ \_\_\_\_\_

Total \$ \_\_\_\_\_

This form must be completed and submitted with Permit Fee prior to construction.

Date Paid \_\_\_\_\_

\*Cost for each additional pressure test = \$100.00 per test.

\*cost for each additional bac-t test = \$125.00

10.3

DEVELOPMENT INFORMATION FORM

CONTRACTOR

Subdivision Name \_\_\_\_\_  
 Location \_\_\_\_\_  
 Developer \_\_\_\_\_ Phone \_\_\_\_\_  
 Address \_\_\_\_\_  
 Dev. Engineer \_\_\_\_\_ Phone \_\_\_\_\_  
 Address \_\_\_\_\_

OFFICE USE ONLY

Date Plans Rec'd at PWSD #3 \_\_\_\_\_ Application Fee \$ \_\_\_\_\_ Date Pd \_\_\_\_\_  
 Fire District \_\_\_\_\_ Approval Date \_\_\_\_\_  
 Approval by District Engineer: \_\_\_\_\_ Date \_\_\_\_\_  
 PWSD #3 Board Approval \_\_\_\_\_ Restrictions or Special Conditions \_\_\_\_\_  
 \_\_\_\_\_  
 Letter of Approval to Developer \_\_\_\_\_ By \_\_\_\_\_  
 Easements or Plat Date Received \_\_\_\_\_ Recorded \_\_\_\_\_  
 Note: A signed & notarized copy of the Plat may be accepted in lieu of a recorded plat  
 Copy of all Applicable Permits, Date Received \_\_\_\_\_ Issuing Body \_\_\_\_\_  
 Construction Permit Fee \$ \_\_\_\_\_ Date Paid \_\_\_\_\_  
 Dev. Contractor \_\_\_\_\_ Phone \_\_\_\_\_  
 Address \_\_\_\_\_  
 Cert. of Ins. \_\_\_\_\_ Bond \_\_\_\_\_  
 Line Staked \_\_\_\_\_ Constr. Starting Date \_\_\_\_\_ Inspector \_\_\_\_\_  
 Pressure Test Date: Date \_\_\_\_\_ Tester \_\_\_\_\_  
 Bacteriological Testing 1<sup>st</sup> \_\_\_\_\_ 2<sup>nd</sup> \_\_\_\_\_  
 Record Drawings \_\_\_\_\_ Added to CAP Maps \_\_\_\_\_  
 Quit Claim Deed Date Recorded \_\_\_\_\_ Book \_\_\_\_\_ Page \_\_\_\_\_

10.4

ANNUAL PERFORMANCE BOND WITH SURETY

KNOW ALL PERSONS BY THESE PRESENTS, That the undersigned \_\_\_\_\_, an individual, firm, partnership or corporation, as Principal, and \_\_\_\_\_ as Surety, are held and firmly bound unto Public Water Supply District No. 3 of Jefferson County, Missouri, Obligee, in the penal sum of Five Thousand and 00/100 Dollars (\$5,000.00) for the payment of which sum the undersigned Principal and Surety bond itself and themselves and their personal representatives, successors and assigns firmly by these presents:

WHEREAS, the undersigned Principal, from the \_\_\_\_\_ day of \_\_\_\_\_ 20\_\_\_\_, to the \_\_\_\_\_ day of \_\_\_\_\_, 20\_\_\_\_, will perform contracting and plumbing services for the Obligee and as such will install facilities of and for the Obligee and as such will further work upon Obligee’s water supply and distribution systems all in accordance with the Obligee’s specifications.

The Condition of this obligation is such that if the above-bounden Principal, its personal representatives, successors and assigns shall in all things well and truly perform the contracting and plumbing services in accordance with Obligee’s specifications from the \_\_\_\_\_ day of \_\_\_\_\_, 20\_\_\_\_, to the \_\_\_\_\_ day of \_\_\_\_\_, 20\_\_\_\_ then this obligation shall be void; otherwise to remain in full force and effect.

Signed and sealed this \_\_\_\_\_ day of \_\_\_\_\_, \_\_\_\_\_.

\_\_\_\_\_  
Principal

BY \_\_\_\_\_

ATTEST:

\_\_\_\_\_  
Secretary

\_\_\_\_\_  
Surety

BY \_\_\_\_\_

ATTEST:

\_\_\_\_\_  
Secretary



10.6

WATER MAIN EASEMENT  
(CORPORATION)

THIS WATER MAIN EASEMENT made on the \_\_\_\_ day of \_\_\_\_\_, 20\_\_\_\_, by and between.

Mailing Address:

of the County of \_\_\_\_\_, State of Missouri, (Owner) and PUBLIC WATER SUPPLY DISTRICT NO. 3 OF JEFFERSON COUNTY, MISSOURI, P. O. Box 920, Arnold, MO 63010 County of Jefferson, State of Missouri (DISTRICT).

OWNER, for and in consideration of the sum of One Dollar and other valuable consideration to said OWNER received and furnished, and given and paid by the DISTRICT, the receipt and sufficiency of which is acknowledge, do/does GRANT, BARGAIN AND SELL, CONVEY AND CONFIRM, unto DISTRICT an EASEMENT over, under, above and through the following described Lots, Tracts and Parcels of land lying, being and situation in the County of Jefferson, State of Missouri.

The EASEMENT and the Lots, Tracts or Parcels of land so burdened by the EASEMENT are described and depicted in Exhibit A, which is a Plat annexed to this EASEMENT and expressly made a part of this EASEMENT.

The EASEMENT is for the purposes of laying, maintaining and removing water pipes and mains, meters, connections, pumps, electric liens and all other water system equipment necessary or convenience to the operation by the DISTRICT of a water supply and distribution system. OWNER agrees to make no claim of ownership to any of the property installed or equipment location in or upon the EASEMENT.

The OWNER may reasonably assign the EASEMENT to other public or private utilities provided that construction by each utility within the easement should conform to all applicable State and Federal regulations as to the separation of such utility's system from other utilities using such EASEMENT.

The DISTRICT shall also have the right of reasonable and direct entry to and exit from the EASEMENT for the purposes of the EASEMENT and shall also have, during the period of initial installation and during subsequent periods for maintenance and removal, the right to use the surface of the EASEMENT and the right to use the surface over areas reasonably adjacent to the EASEMENT so the installation, maintenance and removal be facilitated.

DISTRICT AGREES AT DISTRICT'S SOLE COST AND EXPENSE TO RESTORE THE EASEMENT AND THE SURFACE OF THE EASEMENT AND ALL UTILIZED ADJACENT AREAS AND THE SURFACE OF SAID AREAS TO SUBSTANTIALLY THE SAME CONDITION WHICH EXISTED PRIOR TO ANY INSTALLATION, MAINTENANCE AND REMOVAL.

This EASEMENT shall be permanent and be owned by the DISTRICT and by its successors and assigns and this EASEMENT shall bind the OWNER and the OWNER'S heirs, personal representatives, successors and assigns.

After completion of construction replacement or repairs of the water system, the aforesaid OWNER shall have the free and uninterrupted possession and use of said permanent easement, excepting that no permanent structures or edifices, buildings or sheds shall be erected on or over said permanent easement. Also there shall be no change in the cover over any water main more than 6" plus or minus, without the express written consent of the DISTRICT.

The OWNER for himself, his heirs, successors and assigns, do hereby warrant and covenant to the DISTRICT that he is the owner of the described property and has full right and valid authority to grant this easement and that the DISTRICT may quietly enjoy the premises for the purpose stated herein.

IN WITNESS WHEREOF, the OWNER(S) has their hands and seals the day, month and year first above written.

OWNER: \_\_\_\_\_  
(Signature) (Printed Name and Title)

STATE OF \_\_\_\_\_ )  
COUNTY OF \_\_\_\_\_ )SS

On this \_\_\_\_\_ day of \_\_\_\_\_ in the year \_\_\_\_\_ before me, \_\_\_\_\_,  
A Notary Public in and for said state, personally appeared \_\_\_\_\_,  
known to me to be the person who executed the within EASEMENT in behalf of  
said corporation and acknowledged to me that he/she executed the same for the purposes  
therein stated.

IN TESTIMONY WHEREOF, I have hereunto set my hand and affixed by official seal in the  
County and State aforesaid, the day and year first above written.

\_\_\_\_\_  
Notary Public in and for said County and State

My Commission Expires: \_\_\_\_\_

PUBLIC WATER SUPPLY DISTRICT  
NO. 3 OF JEFFERSON COUNTY, MISSOURI

BY \_\_\_\_\_  
Terry Stotler, Manager

STATE OF \_\_\_\_\_)  
COUNTY OF \_\_\_\_\_)SS

On this day of \_\_\_\_ day of \_\_\_\_\_ in the year \_\_\_\_\_ before me, \_\_\_\_\_,  
a Notary Public in and for said state, personally appeared known to me to be the person who  
executed within EASEMENT in behalf of said corporation and acknowledged to me that he  
executed the same for the purposes therein stated.

IN TESTIMONY WHEREOF, I have hereunto set my hand and affixed my official seal in the  
County and State aforesaid, the day and year first above written.

\_\_\_\_\_  
Notary Public In and for said County and State

My Commission Expires: \_\_\_\_\_

10.6.a

WATER MAIN EASEMENT  
(INDIVIDUAL/MARRIED)

THIS WATER MAIN EASEMENT made on the \_\_\_\_ day of \_\_\_\_\_, 20\_\_\_\_, by and between.

Mailing Address:

of the County of \_\_\_\_\_, State of Missouri, (Owner) and PUBLIC WATER SUPPLY DISTRICT NO. 3 OF JEFFERSON COUNTY, MISSOURI, P. O. Box 920, Arnold, MO 63010 County of Jefferson, State of Missouri (DISTRICT).

OWNER, for and in consideration of the sum of One Dollar and other valuable consideration to said OWNER received and furnished, and given and paid by the DISTRICT, the receipt and sufficiency of which is acknowledge, do/does GRANT, BARGAIN AND SELL, CONVEY AND CONFIRM, unto DISTRICT an EASEMENT over, under, above and through the following described Lots, Tracts and Parcels of land lying, being and situation in the County of Jefferson, State of Missouri.

The EASEMENT and the Lots, Tracts or Parcels of land so burdened by the EASEMENT are described and depicted in Exhibit A, which is a Plat annexed to this EASEMENT and expressly made a part of this EASEMENT.

The EASEMENT is for the purposes of laying, maintaining and removing water pipes and mains, meters, connections, pumps, electric liens and all other water system equipment necessary or convenience to the operation by the DISTRICT of a water supply and distribution system. OWNER agrees to make no claim of ownership to any of the property installed or equipment location in or upon the EASEMENT.

The OWNER may reasonably assign the EASEMENT to other public or private utilities provided that construction by each utility within the easement should conform to all applicable State and Federal regulations as to the separation of such utility's system from other utilities using such EASEMENT.

The DISTRICT shall also have the right of reasonable and direct entry to and exit from the EASEMENT for the purposes of the EASEMENT and shall also have, during the period of initial installation and during subsequent periods for maintenance and removal, the right to use the surface of the EASEMENT and the right to use the surface over areas reasonably adjacent to the EASEMENT so the installation, maintenance and removal be facilitated.

DISTRICT AGREES AT DISTRICT'S SOLE COST AND EXPENSE TO RESTORE THE EASEMENT AND THE SURFACE OF THE EASEMENT AND ALL UTILIZED ADJACENT AREAS AND THE SURFACE OF SAID AREAS TO SUBSTANTIALLY THE SAME CONDITION WHICH EXISTED PRIOR TO ANY INSTALLATION, MAINTENANCE AND REMOVAL.

This EASEMENT shall be permanent and be owned by the DISTRICT and by its successors and assigns and this EASEMENT shall bind the OWNER and the OWNER'S heirs, personal representatives, successors and assigns.

After completion of construction replacement or repairs of the water system, the aforesaid OWNER shall have the free and uninterrupted possession and use of said permanent easement, excepting that no permanent structures or edifices, buildings or sheds shall be erected on or over said permanent easement. Also there shall be no change in the cover over any water main more than 6" plus or minus, without the express written consent of the DISTRICT.

The OWNER for himself, his heirs, successors and assigns, do hereby warrant and covenant to the DISTRICT that he is the owner of the described property and has full right and valid authority to grant this easement and that the DISTRICT may quietly enjoy the premises for the purpose stated herein.

IN WITNESS WHEREOF, the OWNER(S) has their hands and seals the day, month and year first above written.

OWNER: \_\_\_\_\_  
(Signature) (Printed Name and Title)

STATE OF \_\_\_\_\_ )  
COUNTY OF \_\_\_\_\_ )SS

On this \_\_\_\_\_ day of \_\_\_\_\_ in the year \_\_\_\_\_ before me, \_\_\_\_\_,  
A Notary Public in and for said state, personally appeared \_\_\_\_\_,  
\_\_\_\_\_ known to me to be the person who executed the within EASEMENT in behalf of  
said corporation and acknowledged to me that he/she executed the same for the purposes  
therein stated.

IN TESTIMONY WHEREOF, I have hereunto set my hand and affixed by official seal in the  
County and State aforesaid, the day and year first above written.

\_\_\_\_\_  
Notary Public in and for said County and State

My Commission Expires: \_\_\_\_\_

PUBLIC WATER SUPPLY DISTRICT  
NO. 3 OF JEFFERSON COUNTY, MISSOURI

BY \_\_\_\_\_  
Terry Stotler, Manager

STATE OF \_\_\_\_\_ )  
COUNTY OF \_\_\_\_\_ )SS

On this day of \_\_\_\_ day of \_\_\_\_\_ in the year \_\_\_\_\_ before me, \_\_\_\_\_,  
a Notary Public in and for said state, personally appeared known to me to be the person who  
executed within EASEMENT in behalf of said corporation and acknowledged to me that he  
executed the same for the purposes therein stated.

IN TESTIMONY WHEREOF, I have hereunto set my hand and affixed my official seal in the  
County and State aforesaid, the day and year first above written.

\_\_\_\_\_  
Notary Public In and for said County and State

My Commission Expires: \_\_\_\_\_